



TRISIL™ FOR TELECOM EQUIPMENT PROTECTION

FEATURES

- Bidirectional crowbar protection
- Voltage: range from 140V to 400V
- Low V_{BO} / V_R ratio
- Micro capacitance from 15pF to 30pF @ 50V
- Low leakage current : $I_R = 2\mu A$ max
- Holding current: $I_H = 150$ mA min
- Repetitive peak pulse current :
 $I_{PP} = 100$ A (10/1000 μs)

MAIN APPLICATIONS

Any sensitive equipment requiring protection against lightning strikes and power crossing.

These devices are dedicated to central office protection as they comply with the most stressful standards.

Their Micro Capacitance make them suitable for ADSL2+ and low end VDSL.

DESCRIPTION

The SMP100MC is a series of micro capacitance transient surge arrestors designed for the protection of high debit rate communication equipment. Its micro capacitance avoids any distortion of the signal and is compatible with digital transmission line cards (ADSL, VDSL, ISDN...).

SMP100MC series tested and confirmed compatible with Cooper Bussmann Telecom Circuit Protector TCP 1.25A.

BENEFITS

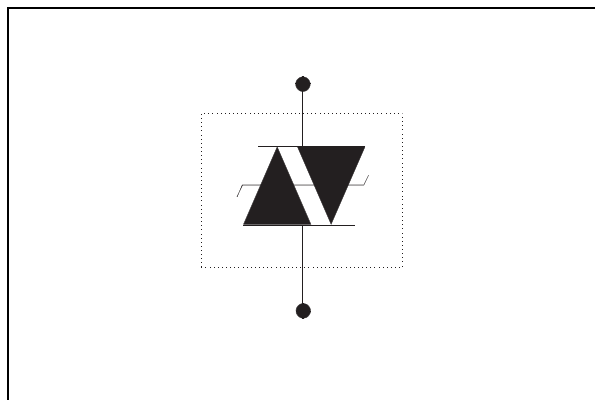
Trisils are not subject to ageing and provide a fail safe mode in short circuit for a better protection. They are used to help equipment to meet main standards such as UL60950, IEC950 / CSA C22.2 and UL1459. They have UL94 V0 approved resin. SMB package is JEDEC registered (DO-214AA). Trisils comply with the following standards GR-1089 Core, ITU-T-K20/K21, VDE0433, VDE0878, IEC61000-4-5 and FCC part 68.



Table 1: Order Codes

Part Number	Marking
SMP100MC-140	ML14
SMP100MC-160	ML16
SMP100MC-200	ML20
SMP100MC-230	ML23
SMP100MC-270	ML27
SMP100MC-320	ML32
SMP100MC-360	ML36
SMP100MC-400	ML40

Figure 1: Schematic Diagram



TM: TRISIL is a trademark of STMicroelectronics.

SMP100MC

Table 2: In compliance with the following standards

STANDARD	Peak Surge Voltage (V)	Waveform Voltage	Required peak current (A)	Current waveform	Minimum serial resistor to meet standard (Ω)
GR-1089 Core First level	2500	2/10 μ s	500	2/10 μ s	0
	1000	10/1000 μ s	100	10/1000 μ s	0
GR-1089 Core Second level	5000	2/10 μ s	500	2/10 μ s	0
GR-1089 Core Intra-building	1500	2/10 μ s	100	2/10 μ s	0
ITU-T-K20/K21	6000	10/700 μ s	150	5/310 μ s	0
	1500		37.5		0
ITU-T-K20 (IEC61000-4-2)	8000	1/60 ns	ESD contact discharge		0
	15000		ESD air discharge		0
VDE0433	4000	10/700 μ s	100	5/310 μ s	0
	2000		50		0
VDE0878	4000	1.2/50 μ s	100	1/20 μ s	0
	2000		50		0
IEC61000-4-5	4000	10/700 μ s	100	5/310 μ s	0
	4000	1.2/50 μ s	100	8/20 μ s	0
FCC Part 68, lightning surge type A	1500	10/160 μ s	200	10/160 μ s	0
	800	10/560 μ s	100	10/560 μ s	0
FCC Part 68, lightning surge type B	1000	9/720 μ s	25	5/320 μ s	0

Table 3: Absolute Ratings ($T_{amb} = 25^{\circ}\text{C}$)

Symbol	Parameter	Value	Unit
I_{PP}	Repetitive peak pulse current	10/1000 μ s	100
		8/20 μ s	300
		10/560 μ s	140
		5/310 μ s	150
		10/160 μ s	200
		1/20 μ s	300
		2/10 μ s	500
I_{FS}	Fail-safe mode : maximum current (note 1)	8/20 μ s	5 kA
I_{TSM}	Non repetitive surge peak on-state current (sinusoidal)	t = 0.2 s	18
		t = 1 s	9
		t = 2 s	7
		t = 15 mn	4
I^2t	I^2t value for fusing	t = 16.6 ms	20
		t = 20 ms	21
T_{stg}	Storage temperature range	-55 to 150	$^{\circ}\text{C}$
T_j	Maximum junction temperature		
T_L	Maximum lead temperature for soldering during 10 s.	260	$^{\circ}\text{C}$

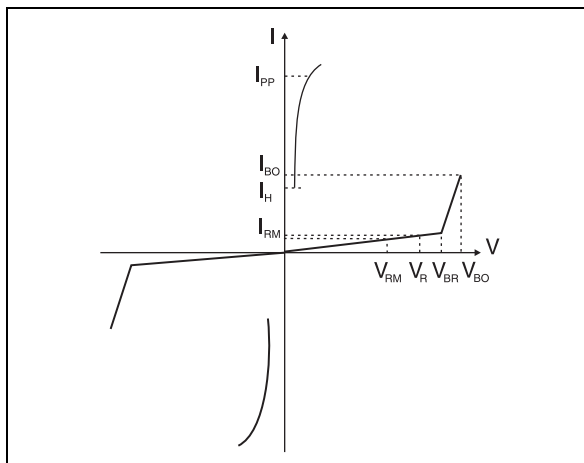
Note 1: in fail safe mode, the device acts as a short circuit

Table 4: Thermal Resistances

Symbol	Parameter	Value	Unit
$R_{th(j-a)}$	Junction to ambient (with recommended footprint)	100	°C/W
$R_{th(j-l)}$	Junction to leads	20	°C/W

Table 5: Electrical Characteristics ($T_{amb} = 25^{\circ}\text{C}$)

Symbol	Parameter
V_{RM}	Stand-off voltage
V_{BR}	Breakdown voltage
V_{BO}	Breakover voltage
I_{RM}	Leakage current
I_{PP}	Peak pulse current
I_{BO}	Breakover current
I_H	Holding current
V_R	Continuous reverse voltage
I_R	Leakage current at V_R
C	Capacitance



Types	$I_{RM} @ V_{RM}$ max.		$I_R @ V_R$ max. note 1		Dynamic V_{BO} max. note 2	Static $V_{BO} @ I_{BO}$ max. max. note 3		I_H min. note 4	C typ. note 5	C typ. note 6
	μA	V	μA	V	V	V	mA	mA	pF	pF
SMP100MC-140	2	126	5	140	180	175	800	150	30	60
SMP100MC-160		144		160	205	200			25	50
SMP100MC-200		180		200	255	250			20	45
SMP100MC-230		207		230	295	285			20	40
SMP100MC-270		243		270	345	335			20	40
SMP100MC-320		290		320	400	390			15	35
SMP100MC-360		325		360	460	450			15	35
SMP100MC-400		360		400	540	530			15	30

Note 1: I_R measured at V_R guarantee $V_{BR} \min \geq V_R$

Note 2: see functional test circuit 1

Note 3: see test circuit 2

Note 4: see functional holding current test circuit 3

Note 5: $V_R = 50\text{V}$ bias, $V_{RMS} = 1\text{V}$, $F = 1\text{MHz}$

Note 6: $V_R = 2\text{V}$ bias, $V_{RMS} = 1\text{V}$, $F = 1\text{MHz}$

Figure 2: Pulse waveform

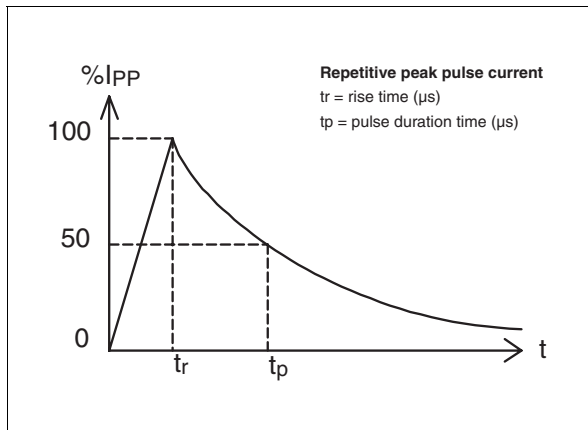


Figure 3: Non repetitive surge peak on-state current versus overload duration

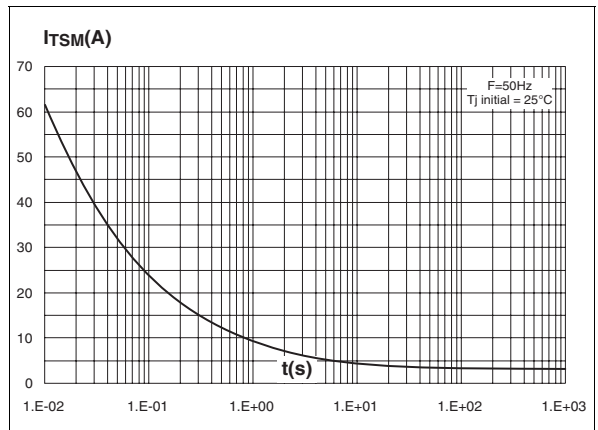


Figure 4: On-state voltage versus on-state current (typical values)

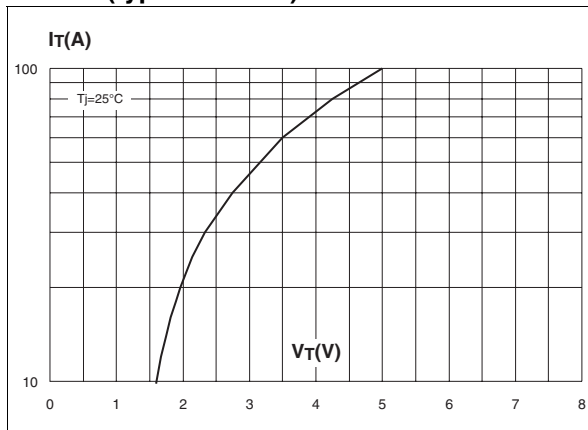


Figure 5: Relative variation of holding current versus junction temperature

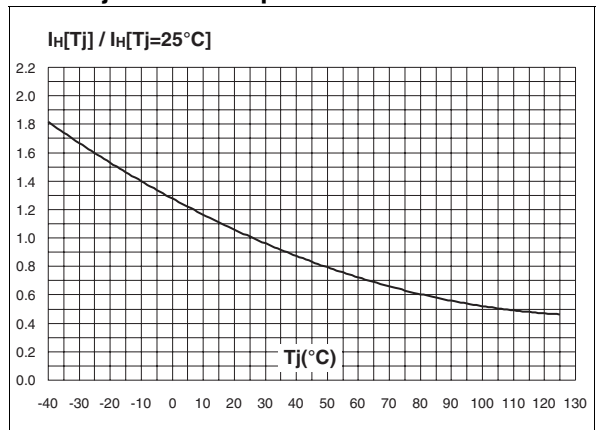


Figure 6: Relative variation of breakover voltage versus junction temperature

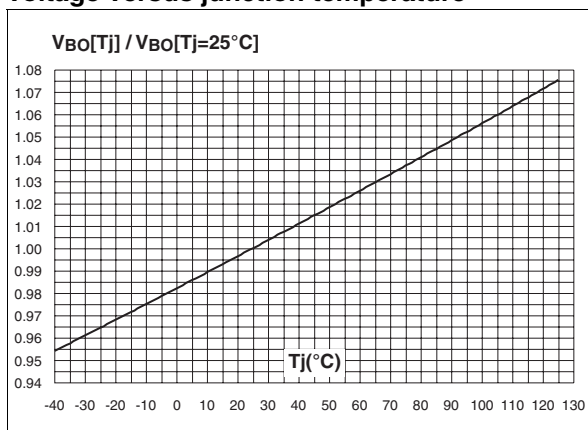


Figure 7: Relative variation of leakage current versus junction temperature (typical values)

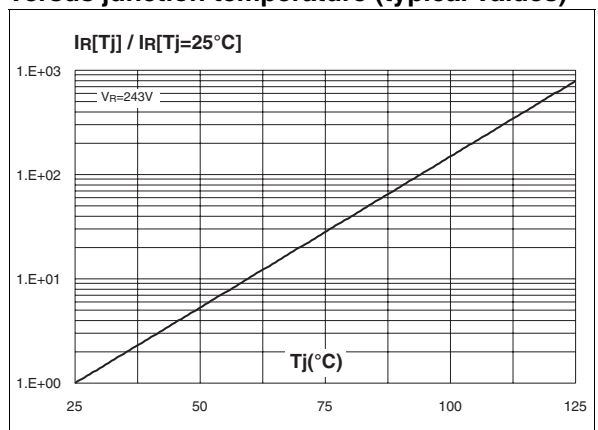


Figure 8: Variation of thermal impedance junction to ambient versus pulse duration (Printed circuit board FR4, SCu=35µm, recommended pad layout)

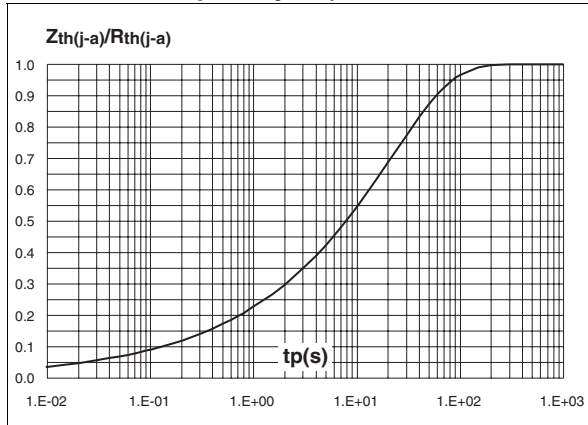
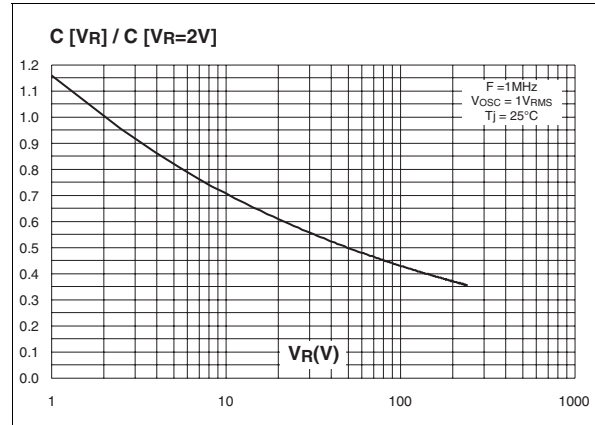
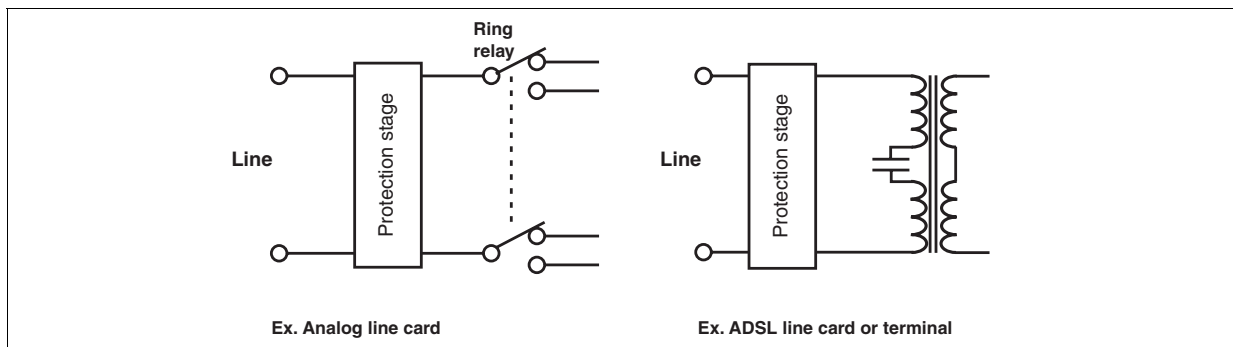


Figure 9: Relative variation of junction capacitance versus reverse voltage applied (typical values)

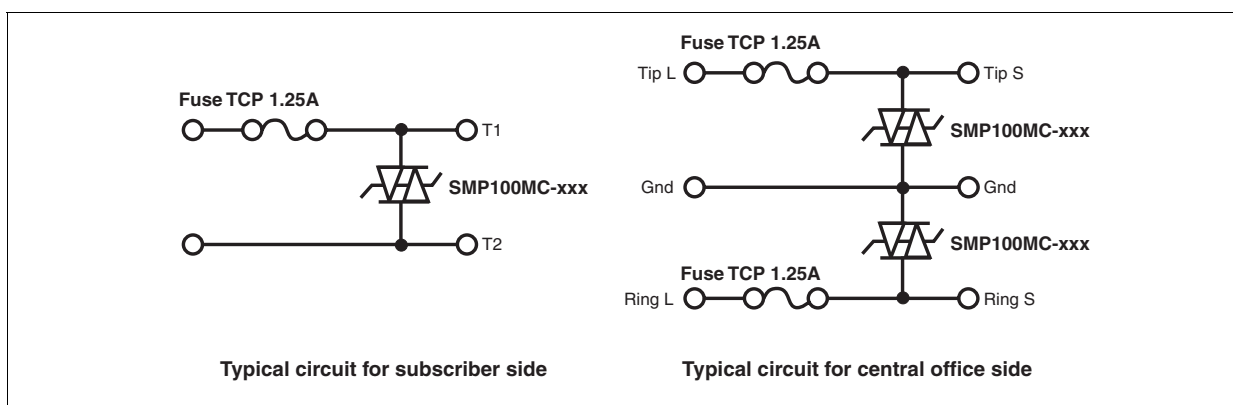


APPLICATION NOTE

In wireline applications, analog or digital, both central office and subscriber sides have to be protected. This function is assumed by a combined series / parallel protection stage.

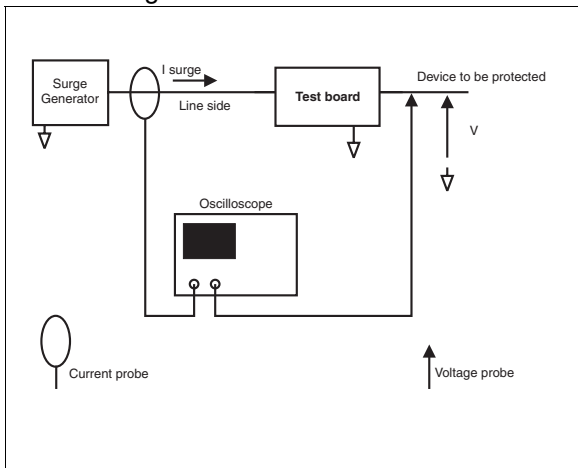


In such a stage, parallel function is assumed by one or several Trisil, and is used to protect against short duration surge (lightning). During this kind of surges the Trisil limits the voltage across the device to be protected at its break over value and then fires. The fuse assumes the series function, and is used to protect the module against long duration or very high current mains disturbances (50/60Hz). It acts by safe circuits opening. Lightning surge and mains disturbance surges are defined by standards like GR1089, FCC part 68, ITU-T K20.

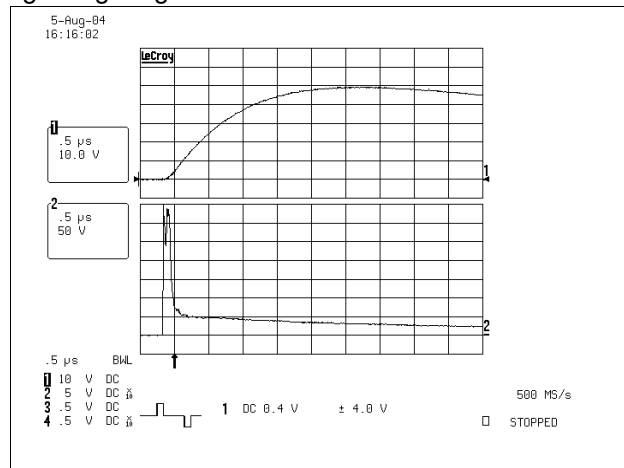


SMP100MC

Following figure shows the test method of the board having Fuse and Trisil.



Following curve shows the turn on of the Trisil during lightning surge.



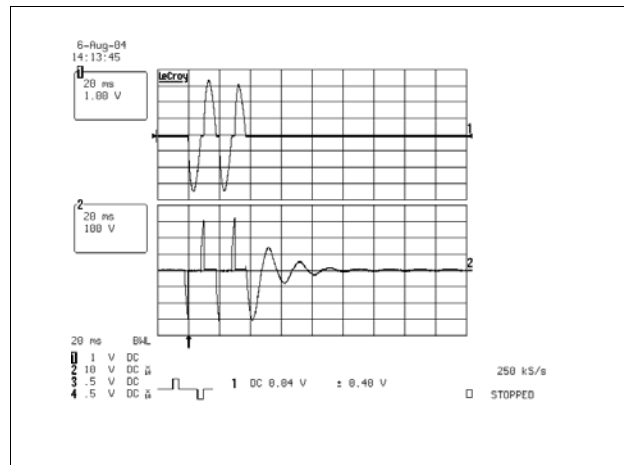
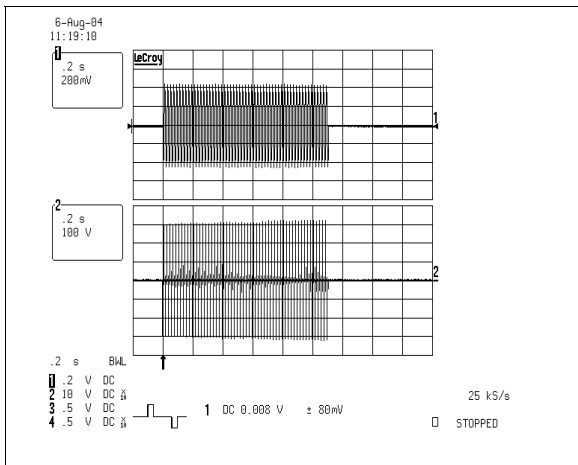
These topologies, using SMP100MC from ST and TCP1.25A from Cooper Bussmann, have been functionally validated with a Trisil glued on the PCB. Following example was performed with SMP100MC-270 Trisil. For more information, see Application Note AN2064.

Test conditions:
2/10µs + and -2.5 and 5kV 500A (10 pulses of each polarity), T_{amb} = 25°C

Test result:
Fuse and Trisil OK after test in accordance with GR1089 requirements

Following curve shows Trisil action while the fuse remains operational.

In case of high current power cross test, the fuse acts like a switch by opening the circuit.



Test conditions:
600V 3A 1.1s (first level), T_{amb} = 25°C

Test conditions:
277V 25A (second level), T_{amb} = 25°C

Test result:
Fuse and Trisil OK after test in accordance with GR1089 requirements

Test result:
Fuse safety opened and Trisil OK after test in accordance with GR1089 requirements

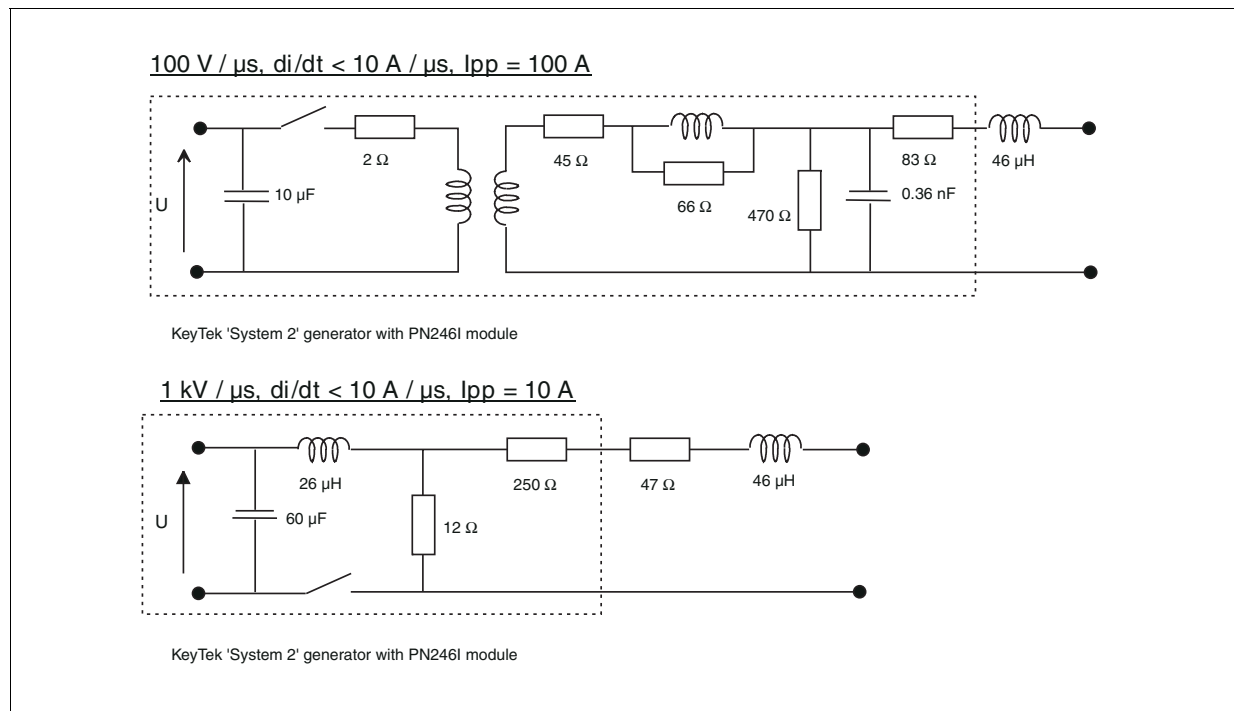
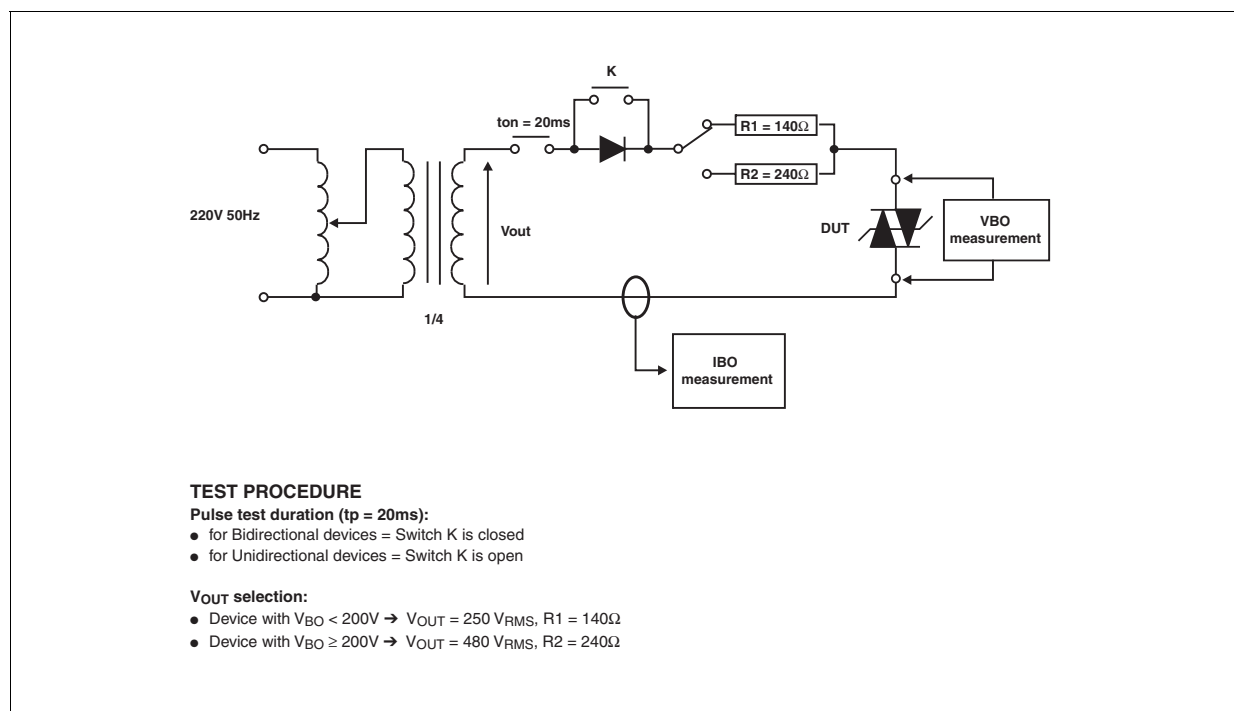
Figure 10: Test circuit 1 for Dynamic I_{BO} and V_{BO} parametersFigure 11: Test circuit 2 for I_{BO} and V_{BO} parameters

Figure 12: Test circuit 3 for dynamic I_H parameter

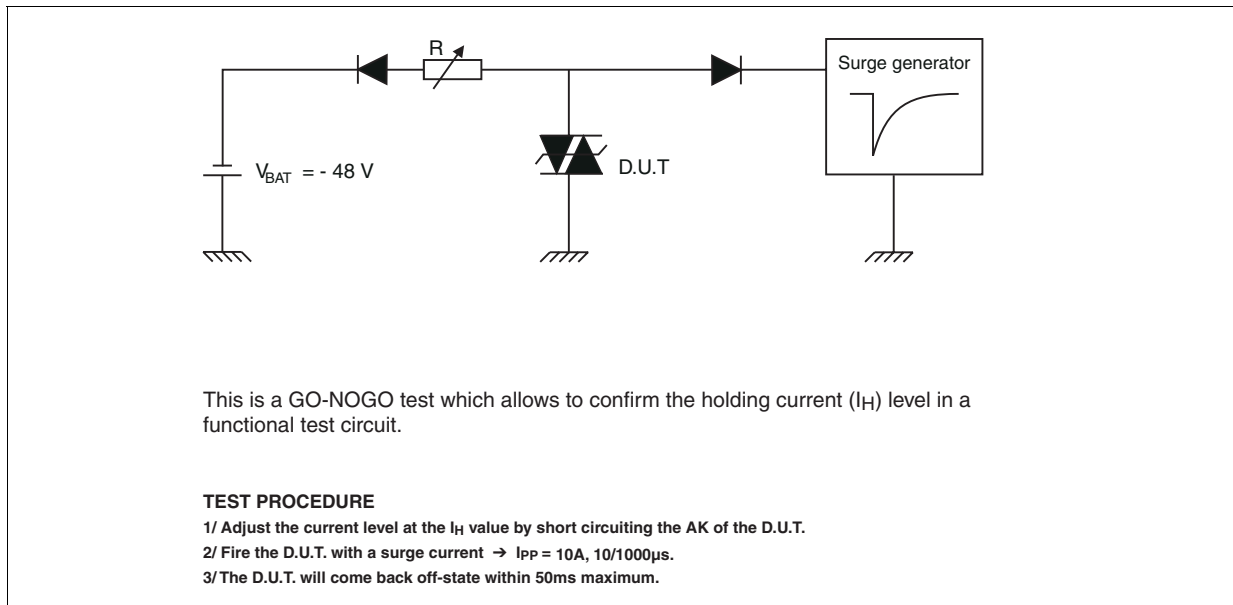


Figure 13: Ordering Information Scheme

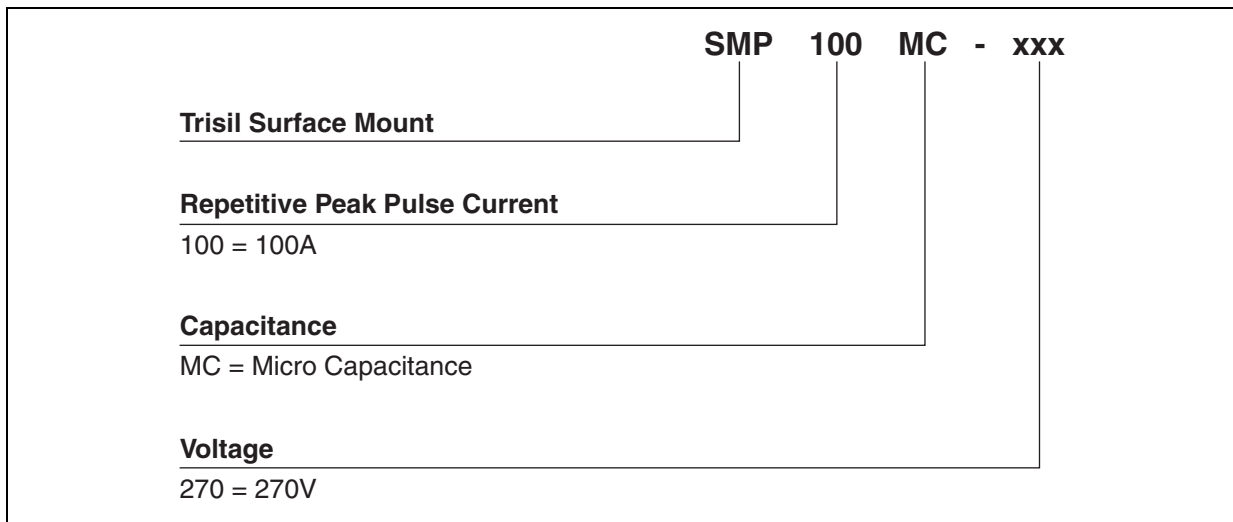


Figure 14: SMB Package Mechanical data

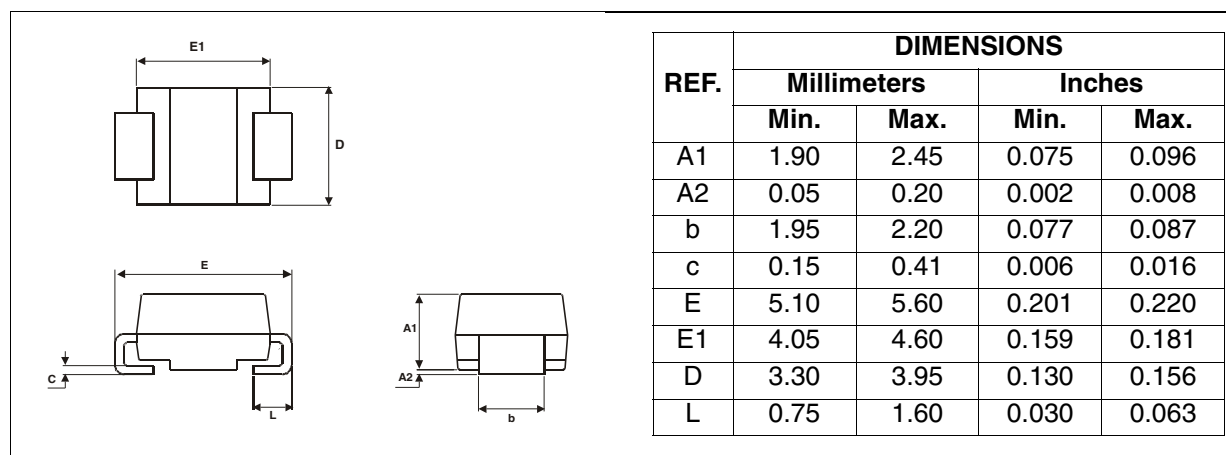


Figure 15: Foot Print Dimensions (in millimeters)

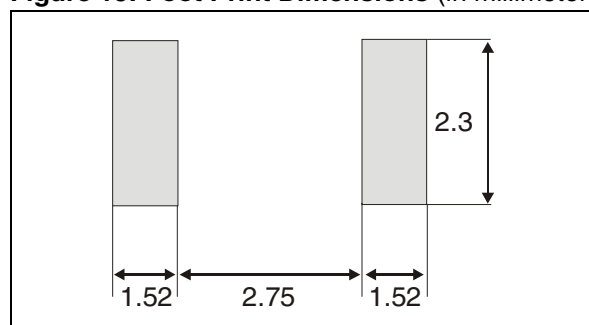


Table 6: Ordering Information

Part Number	Marking	Package	Weight	Base qty	Delivery mode
SMP100MC-140	ML14	SMB	0.11 g	2500	Tape & reel
SMP100MC-160	ML16				
SMP100MC-200	ML20				
SMP100MC-230	ML23				
SMP100MC-270	ML27				
SMP100MC-320	ML32				
SMP100MC-360	ML36				
SMP100MC-400	ML40				

Table 7: Revision History

Date	Revision	Description of Changes
September-2003	0B	First issue.
14-Dec-2004	1	Absolute ratings values, table 3 on page 2, updated.
11-May-2005	2	New types introduction.
20-Jun-2005	3	Telecom Circuit Protector added
05-Jan-2006	4	SMP100MC-320 / 360 / 400 in full production ("in development" mention removed)

Information furnished is believed to be accurate and reliable. However, STMicroelectronics assumes no responsibility for the consequences of use of such information nor for any infringement of patents or other rights of third parties which may result from its use. No license is granted by implication or otherwise under any patent or patent rights of STMicroelectronics. Specifications mentioned in this publication are subject to change without notice. This publication supersedes and replaces all information previously supplied. STMicroelectronics products are not authorized for use as critical components in life support devices or systems without express written approval of STMicroelectronics.

The ST logo is a registered trademark of STMicroelectronics.
All other names are the property of their respective owners

© 2006 STMicroelectronics - All rights reserved

STMicroelectronics group of companies

Australia - Belgium - Brazil - Canada - China - Czech Republic - Finland - France - Germany - Hong Kong - India - Israel - Italy - Japan -
Malaysia - Malta - Morocco - Singapore - Spain - Sweden - Switzerland - United Kingdom - United States of America

www.st.com